

VEGA

MODEL 2796500



RESOLVER TO DIGITAL INTERFACE

- Works with Harowe/Danaher, Tamagawa, Kerfott, Singer, AMCI or most any Synchro/Resolver
- Incremental encoder output signals
- Makes resolvers as easy to use as an encoder
- Jumper Selectable counts 1000, 1024, 2000, 2048, 4000, 4096, 8000, and 8192 A-quad-B with Index and complements
- Jumper Selectable Excitation Frequency including 2.5, 5.0, and 10 kHz
- Removable Screw Terminals

With the VEGA 2796500 converter you can have both the ruggedness of a resolver and the digital simplicity of an encoder interface. The 2796500 can be used with almost any resolver. The INDEX/MARKER pulse (Channel Z) will occur once per transducer cycle at the zero degree position.

2796500 SPECIFICATIONS

Excitation:	2.5, 5, or 10 kHz @ 3.6 vpp
Resolver Input:	0.8 to 18 vpp
Power Requirements:	5 vDC @ 250 mA (2796500-05) 24 vDC @ 125 mA (2796500-24)
Drive Capacity:	200 mA Peak
Mechanical:	4.10 x 0.75 x 5.00
Accuracy:	+/- 3 arc minutes typical

RESOLVER TO ENCODER CONVERTER FOR MACHINE TOOL, POSITIONING, AND TRANSFER LINE APPLICATIONS

*** APPLICATIONS ***

- Ideal For Closed Loop Positioning Systems
- Machine Tools
- Nuclear Applications
- PLC Positioning Control
- Index/Rotary Tables
- Tracking/Telescope/Telemetry Systems
- Transfer Lines
- Positioning Systems
- Robotic Applications
- Dispensing Systems



*** ADVANCED FEATURES ***

- Incremental Encoder Output (*Absolute within 1 Resolver cycle)
- Non-Phase Locked Loop Design for Faster Loop Closure (Less than 50 uSec @ 10 kHz)
- High Resolution and Highly Accurate
- Tuned Filter for Noise Immunity
- A-Quad-B, Index and Complements
- TTL/Line Driver Outputs
- Quadrature encoder signals to 4 mHz
- Single vDC Supply Operation
- Loss of Phase Detection
- Fault Signal Output (Line Driver, and Active Pull-Up)
- Status LED's for Power, A, B, Z, Signal HI, Signal MID, and Fault
- Configurable Fault signal conditioning for Fail-Safe operations
- Compact Design Only 17.5 mm wide

* Tracking limited to +/- 0.25 Resolver cycle with power off

CONVERTER TRACKING RATE

The tracking rate is a function of the excitation frequency. With a 2.5 kHz excitation the tracking rate would be 9,600 rpm. With a 5.0 kHz excitation the tracking rate would be 19,200 rpm. With a 10.0 kHz excitation the tracking rate would be 38,400 rpm.

PRICING AND DELIVERY

Model	Description	Price
2796500-05	+5 vDC Resolver to Digital	\$550.00
2796500-24	+24 vDC Resolver to Digital	\$575.00

Mating Connectors Included.

PEOPLE IN CONTROL OF MOTION

VEGA 2796500 RESOLVER TO ENCODER SPECIFICATIONS AND CONNECTIONS

P1 POWER CONNECTOR

PIN#	FUNCTION	COLOR
1	+5 vDC IN (2796500-05 Only)	RED
2	DC Ground	BLK
3	Shield In	SHLD
4	No Connection	N/A
5	No Connection	N/A
6	No Connection	N/A
7	No Connection	N/A
8	!Fault Output	ORG
9	I/O vDC IN	BLU/WHT
10	+24 vDC IN (2796500-24 Only)	BLU

P2 ENCODER CONNECTOR

PIN#	FUNCTION	COLOR
1	Channel A+	Grey
2	Channel A-	Violet
3	Channel B+	Yellow
4	Channel B-	Orange
5	Channel Z+	Blue
6	Channel Z-	Green
7	Shield Out	SHLD
8	No Connection	N/A
9	No Connection	N/A
10	No Connection	N/A
11	No Connection	N/A
12	No Connection	N/A
13	No Connection	N/A

P4 RESOLVER CONNECTOR

PIN#	FUNCTION	COLOR
1	Feedback LO	Yel/Wht
2	Feedback HI	Red/Wht
3	Shield Out	SHLD
4	Sine LO	Black
5	Sine HI	Red
6	Shield Out	SHLD
7	Cosine HI	Yellow
8	Cosine LO	Blue
9	Shield Out	SHLD
10	DC Ground OUT	N/A
11	+5 vDC OUT	N/A

FAULT SIGNAL INTERFACE

TRI-STATE A-QUAD-B FAULT SIGNAL

The 2796 board will Tri-State the A-Quad-B signals during a Fault condition. This allows receiving devices with A-Quad-B level detection to detect feedback faults without additional fault circuitry.

FAULT SIGNAL OUTPUT (P1-8)

The 2796 will open the contacts of the solid state relay between P1-8 and P1-9 to indicate a fault has occurred. The relay can drive 600 mAmps. The source voltage must be provided on P1-9 and can range from 5-25 vDC.

QUADRATURE OUTPUT

The VEGA 2796 series of converter boards use RS-422-A differential drivers to provide 40 mA into a 100 ohm differential load. These outputs are also TTL compatible.

The output latency is dependent on the excitation frequency. At 2.5 kHz the response will be less than 200 uSec and at 10.0 kHz the response will be less than 50 uSec.

Quadrature is provided via Channel A+, Channel A-, Channel B+ and Channel B-. A count is considered to occur whenever there is a transition in either the Channel A or Channel B output signals. The Channel Z (Index) occurs once per resolver cycle. The phase relationship of the two signals indicates the direction of motion as shown in the figure below.

QUADRATURE OUTPUT FORMAT

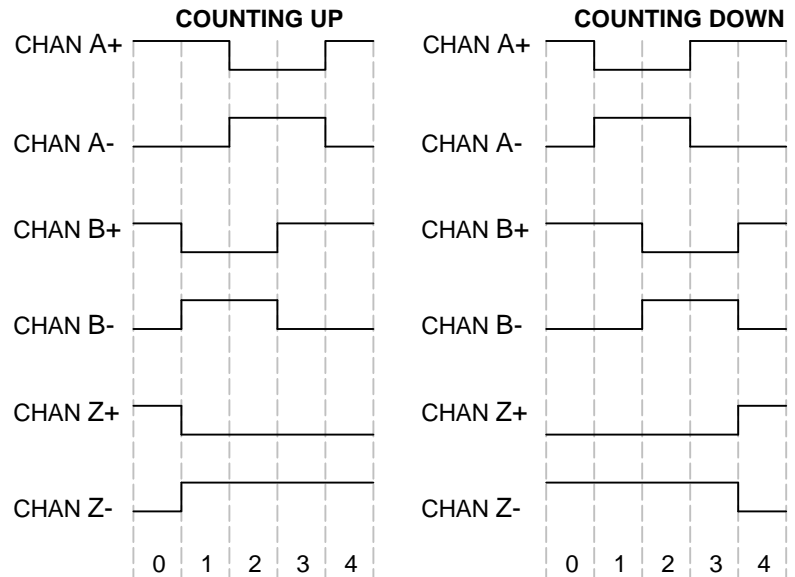

VEGA
 1270 Souter Blvd.
 Troy, MI 48083
 248.585.3600

JUMPER SETTINGS (JB1)

FREQUENCY SELECTION (JB1-1 & JB1-2)

The 2796 converters provide selectable excitation frequencies of 2.5, 5.0 and 10.0 kHz via JB1-1 and JB1-2 jumpers.

DECIMAL/BINARY SELECTION (JB1-3)

Installing JB1-3 jumper selects binary counting mode to provide selection between 256, 512, 1024, and 2048 line counts. Removing jumper JB1-3 selects the decimal counting mode to provide selection between 250, 500, 1000, and 2000 line counts.

LINE COUNT SELECTION (JB1-4 & JB1-5)

The 2796 converters board provides 8 jumper selectable line counts. Binary counts are selected by installing JB1-3, while jumpers JB1-4 and JB1-5 select the line count. Most systems are set to the x4 quadrature counting mode so that the effective quadrature counts are 4 times the line count of the encoder.

RESERVED (JB1-6 thru JB1-9)

On the 2796500 converter board Jumpers JB1-6 thru JB1-9 are reserved and should have all jumpers removed

ACTIVE FILTER SELECTION (JB1-10)

The 2796 also provides jumper selection of the active filter network for the return signal to provide the maximum noise immunity at the selected frequency. For the typical Resolver application operating at 2.5 kHz JB1-10 jumper should be installed. For excitation frequencies above 2.5 kHz JB1-10 jumper should be removed.

INTERNAL GAIN SELECTION (JB1-11 & 12)

The 2796 series of converters provide selectable gain selection via JB1 jumpers 11 and 12. Installing a jumper on JB1-11 selects a gain of x0.25 Installing a jumper on JB1-12 selects a gain of x1.0 and removing the jumpers JB1-11 and JB1-12 selects a gain of x4.0

See Figure 1.0 for JB1 Jumper Chart Below.

THEROY OF OPERATION

The return signal level is monitored for high signal level (HSG LED), and low signal level (FLT LED). During a low level detection or loss of power to the board the fault relay contacts will open (connector P1 terminal 8 and 9). The A-Quad-B outputs will be tri-stated during the fault condition.

The return signal is internally amplified by the coarse gain selection (JB1-11 & JB1-12) and the ADJ potentiometer. It is then passed thru an active filter network to reduce noise. The advanced phase tracking algorithm tracks the phase shifted return and interpolates A-Quad-B pulses based on the phase shifted return.

The return signal level is monitored for high signal level (HI LED), and low signal level (LO LED). During a low level detection or loss of power to the board the fault relay contacts will open (P1-8 and P1-9), and the A-Quad-B outputs will be tri-stated.

The Z channel (Marker Pulse) will occur once per resolver cycle (resolver pole pair).

POWER UP SEQUENCE

- 1) The 2796 allows 50 mSec for the power to stabilize
- 2) The 2796 then starts the Sine and Cosine excitations with the sine being in sync with the command square wave
- 3) The 2796 will then initialize the A-Quad-B outputs with channel A and B active (high state) and the Z channel (index/marker) to inactive (low state).
- 4) The 2796 will then interpolate out A-Quad-B counts to the nearest resolver null to indicate absolute shaft position

FUNCTION	1	2	3	4	5	6	7	8	9	10	11	12	QUADRATURE COUNTS
2.5 kHz Excitation	0	0											
5 kHz Excitation	1	0											
10 kHz Excitation	0	1											
Reserved	1	1											
Decimal Count			0										
Binary Count			1										
250/256 Lines				0	0								1000/1024 Counts
500/512 Lines				1	0								2000/2048 Counts
1000/1024 Lines				0	1								4000/4096 Counts
2000/2048 Lines				1	1								8000/8192 Counts
Reserved						0	0	0	0				
10.0 kHz LPF										0			
2.5-5.0 kHz LPF										1			
x 4.0 Gain Select											0	0	
x 0.25 Gain Select											1	0	
x 1.0 Gain Select											0	1	
Reserved											1	1	

Figure 1.0

Indicates Default

RESOLVER SET-UP PROCEDURE

- 1) With the power turned off. Install the 2796 board as described in the application drawing and complete the following steps.
- 2) Select the excitation frequency by setting JB1-1 and JB1-2 jumpers as described in the JUMPER SETTINGS (see jumper table Fig. 1.0). 10.0 kHz is the DEFAULT setting with Jumper JB1-1 removed and JB1-2 installed.
- 3) Select the counting style of Binary or Decimal by setting JB1-3 (see jumper table Fig. 1.0). Binary is the DEFAULT setting with the JB1-3 installed.
- 4) Select the line count per revolution by setting JB1-4 and JB1-5 (see jumper table Fig. 1.0). 2048 lines per revolution (8192 quadrature counts per revolution) is the DEFAULT setting with JB1-4 installed and JB1-5 installed.
- 5) Jumpers JB1-6, JB1-7, JB1-8, and JB1-9 are reserved on the 2796500 board and should be removed
- 6) Select the passive filter setting by JB1-10 for the corresponding frequency setting. The DEFAULT setting is set to 10.0 kHz and JB1-10 is removed.
- 7) Select the Internal Gain Selection by setting the JB1-11 and JB1-12 jumpers as described in the JUMPER SETTINGS section. The DEFAULT setting is for a board set to x1 Gain JB1-12 installed (See step 8 for detailed set-up instructions).
- 8) Starting with the JB1-11 jumper removed and the JB1-12 jumper installed (x1.0 Gain Selection). Turn the ADJ Potentiometer fully counter-clockwise (12 turn Pot). Observing the LO, MID and HI LEDs apply power to the board.
- 8) Turn the ADJ potentiometer clock-wise until the (Green) MID LED turns on and the LO LED turns off. Continue turning the ADJ clock-wise until the HI LED turns on. Now turn the ADJ potentiometer counter-clockwise to position the ADJ in the middle of the MID LED band.
- 9) **NOTE:** If you are unable to get the MID or HI LED to turn on, remove both JB1-11 and JB1-12 jumpers (x4.0 Gain Selection).
- 10) Phase the position loop if necessary by reversing the Sine HI and Sine LO wires to reverse the count direction. At this point the basic set-up is complete and the position loop can now be closed.
- 11) The amplitude balance is factory adjusted and should not require further adjustments. To adjust the amplitude balance of the 2796 board, use an AC RMS meter and record the value of PB- to PB+. Then measure the value of PA- to PA+ and adjust the balance pot (BAL) on the 2796 to match the value recorded for PB- to PB+.

Note: If the MID or HE LEDs are turned on, remove JB1-12 and install JB1-11 (x0.25 Gain Selection).

LED STATUS INDICATORS

CHA = Channel A State Indicator
CHB = Channel B State Indicator
CHZ = Channel Z (Index/Marker) Indicator
PWR = Power Status Indicator

FLT = 1 Flash = Low Signal Continuous
2 Flash = High Signal Continuous
3 Flash 2796512 Only
PUPV Fault (Power Up Position Valid)
Power up position detected +/- 15 Counts of Error
4 Flash = Low Signal Intermittent
5 Flash = High Signal Intermittent

LO = Loss of Signal Indicator
MID = Return Signal Proper Indicator
HSG = High Signal Indicator

TEST POINTS

ACOM = Analog Ground
PA+ = Sine HI (3.6 vDC Peak to Peak)
PA- = Sine LO (3.6 vDC Peak to Peak)
PB+ = Cosine HI (3.6 vDC Peak to Peak)
PB- = Cosine LO (3.6 vDC Peak to Peak)

SIG = Signal Return (0.8-18.0 vDC Peak to Peak)
ST1 = Stage 1 Signal (3.8 vDC Peak to Peak)

TROUBLE SHOOTING

SYMPTOM	CHECKS	SOLUTION
No Power LED	Check +5 vDC on 2796500-05 or +24 vDC on 2796500-24	vDC Present → Check Fuses F4 and F5
LO LED (Low Signal) Continuous	Remove power and disconnect P4 from the board. Ohm the wires on P4-1 and P4-2 and note value.	Resistance values are less than 30 ohms – Check for shorts between P4-1 and P4-2 as well as ground.
	Remove power and disconnect P4 from the board. Ohm the wires on P4-4 and P4-5 and note value. Ohm the wires on P4-7 and P4-8 note value.	Resistance values are less than 30 ohms – Check for shorts between P4-4 and P4-5 as well as ground. Check for shorts between P4-7 and P4-8 as well as ground.
	Apply power and measure between P4-4 and P4-5 for 2.9 vRMS	Signal not present → Board Failure – Replace board
	Apply power and measure between P4-7 and P4-8 for 2.9 vRMS	Signal not present → Board Failure – Replace board
	Check “ST1” test point for 3.6 volts peak to peak	Repeat Step 8 of the Resolver Set-Up Procedure
LO LED (Low Signal) Intermittent	Remove power and disconnect P4 from the board. Ohm the wires on P4-4 and P4-5 and note value. Ohm the wires on P4-7 and P4-8 note value.	Resistance values differ by more than 3 ohms of each other → Check resolver windings – Replace cables and/or resolver
	Check “ST1” test point for bounce	Repeat step 11 of the Resolver Set-Up Procedure
Cyclic Error	Check “ST1” test point for bounce	Repeat step 11 of the Resolver Set-Up Procedure
	Remove power and disconnect P4 from the board. Ohm the wires on P4-4 and P4-5 and note value. Ohm the wires on P4-7 and P4-8 note value.	Resistance values are less than 30 ohms – Check for shorts between P4-4 and P4-5 as well as ground. Check for shorts between P4-7 and P4-8 as well as ground.
	Remove power and disconnect P4 from the board. Ohm the wires on P4-4 and P4-5 and note value. Ohm the wires on P4-7 and P4-8 note value.	Resistance values differ by more than 3 ohms of each other → Check resolver windings – Replace cables and/or resolver
HSG LED (High Signal) Continuous	Check “ST1” test point for 3.6 volts peak to peak	Repeat Step 8 of the Resolver Set-Up Procedure
HSG LED (High Signal) Intermittent	Check “ST1” test point for 3.6 volts peak to peak	Follow procedures described in the LO LED (Low Signal) Intermittent section
MID LED (Signal Midpoint) Continuous	Signal Proper	No Problem... Life is Good
MID LED (Signal Midpoint) Intermittent	Check “ST1” test point for bounce	Repeat step 11 of the Resolver Set-Up Procedure
Feedback Polarity is Reversed	None	Swapping the P4-4 (Sine HI) with the P4-5 (Sine LO) wires will reverse the feedback polarity

APPLICATION INTERFACE

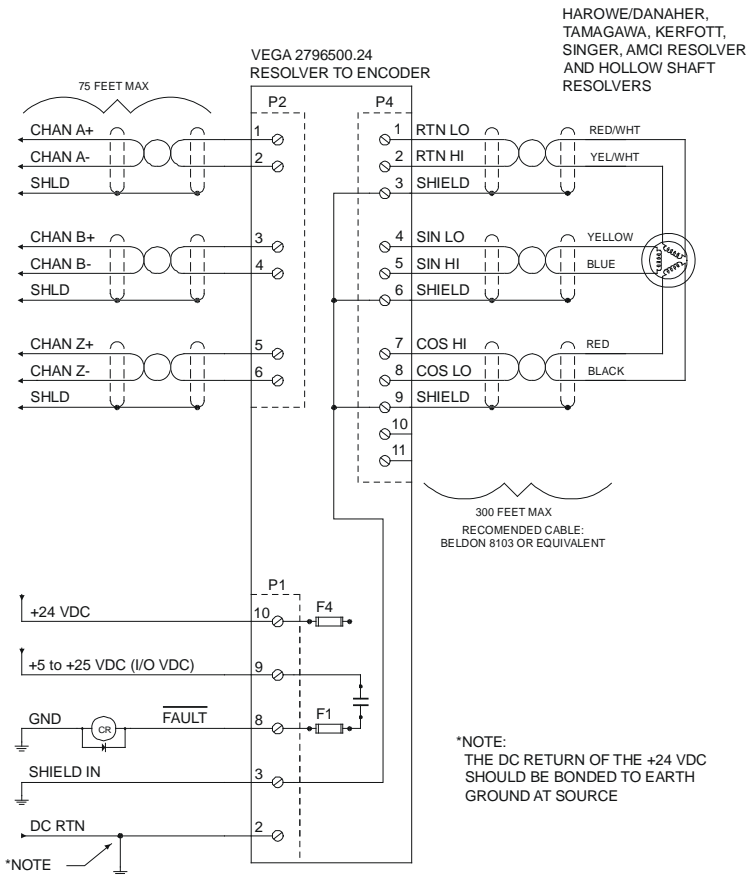

DISASSEMBLY



Firmly press the center of the latch hook down and slide towards the center of the enclosure.

NOTE: Use caution not to drop the spring under the latch hook.

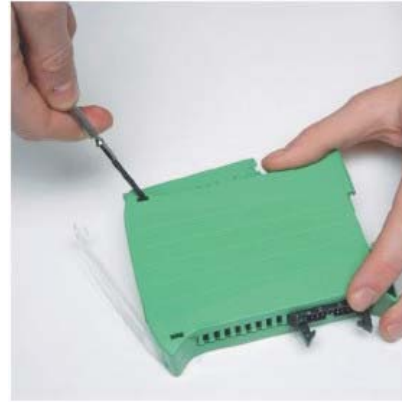

Using a small flat head screwdriver release all four of the enclosure cover hooks.

NOTE: Use caution to avoid breaking the cover hooks.

MECHANICAL

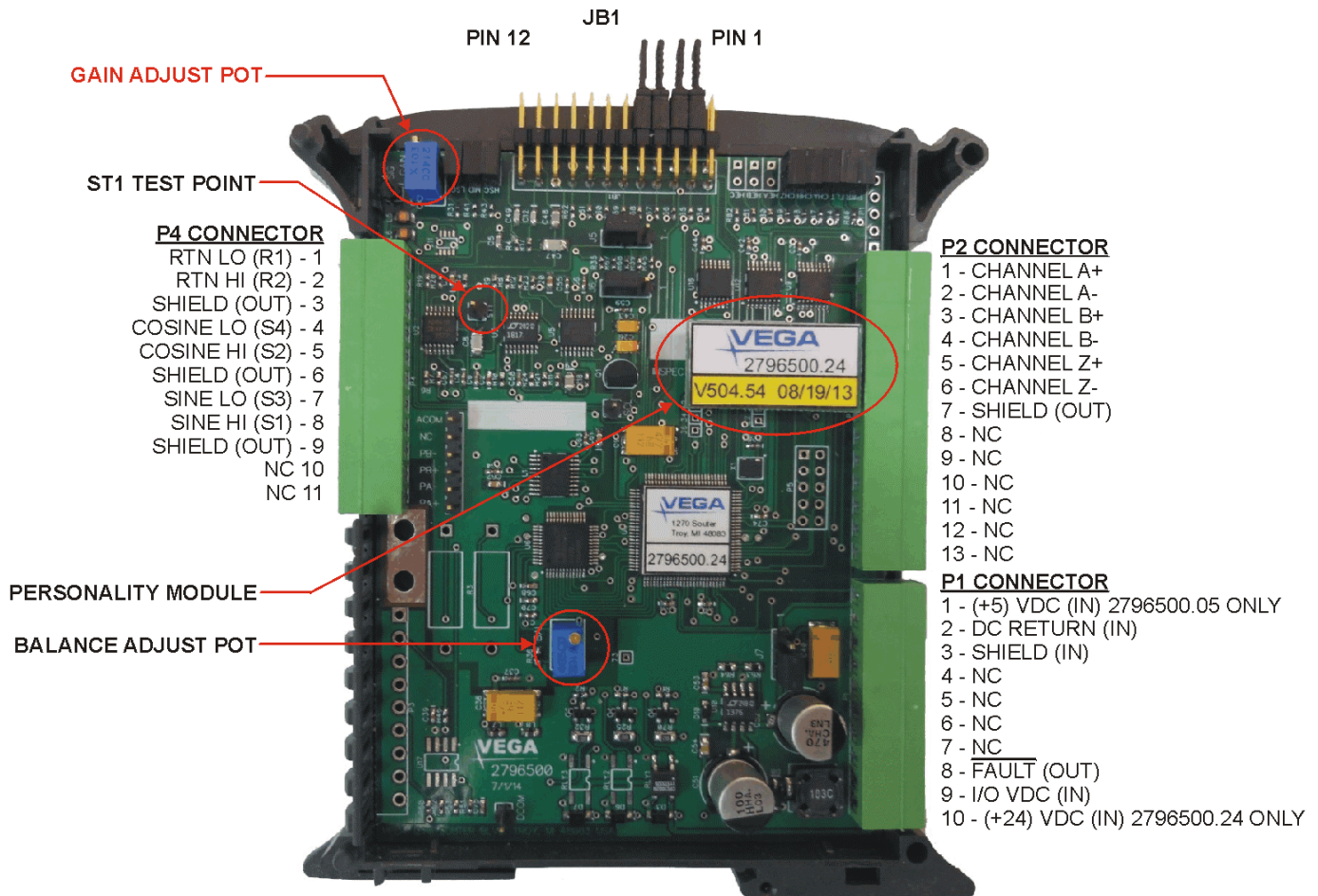

POWER REQUIREMENTS

The 2796500-05 converter requires +5 vDC supply @ 250 mAmp for operation. The 2796500-24 converter requires +24 vDC supply @ 125 mAmp for operation. The supplied power should have less than 50 mVolts of noise and drift.

Recommended Power Supplies (If Required)

TDK DSP30-5 (+5 vDC @ 3 Amps)

TDK DSP60-24 (+24 vDC @ 2.5 Amps)

CABLE SPECIFICATIONS

The 2796 series of converters provide stable and precise sine and cosine excitations. These signals and the return signal are analog and proper routing and shielding techniques should be observed. Shielded twisted pair cables should be used for all interface signals.

Recommended Cable

Shielded (3) Twisted Pair with Drain Wire
Belden #8103 or equivalent



Monday-Friday 8:00am to 6:00pm Eastern