

VEGA

MODEL 2790505

RESOLVER TO ABSOLUTE ENCODER CONVERTER with SSI INTERFACE

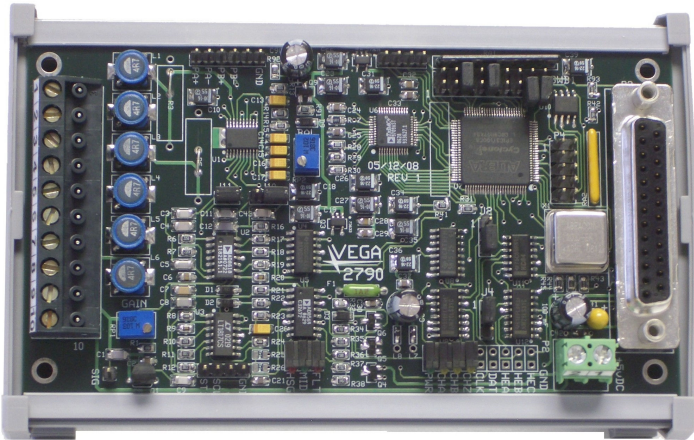

RESOLVER TO DIGITAL INTERFACE

- Works with R11, R25, or most any Synchro/Resolver
- 25 Bit SSI (Synchronous Serial Interface)
- A-Quad-B, Index and Complements
- Makes resolvers as easy to use as an encoder
- Jumper Selectable quadrature counts 1000, 1024, 2000, 2048, 4000, 4096, 8000, and 8192 A-quad-B with Index and complements
- Jumper Selectable Excitation Frequency including 2.5, 5.0, and 10 kHz

With the VEGA 2790505 converter you can have both the ruggedness of a resolver and the digital simplicity of an encoder interface. The 2790505 can be used with almost any resolver. The INDEX/MARKER pulse (Channel Z) will occur once per transducer cycle at the zero degree position.

2790505 SPECIFICATIONS

Excitation:	2.5, 5, or 10 kHz @ 3.6 vpp
Resolver Input:	0.8 to 18 vpp
Power Requirements:	5 vDC @ 250 mA
Drive Capacity:	200 mA
Mechanical:	2.825 x 4.75 x 1.00
Accuracy:	+/- 3 arc minutes
Weight:	80 grams (148 w/DIN)

CONVERTER TRACKING RATE

The tracking rate is a function of the excitation frequency and quadrature counts. With a 2.5 kHz excitation and 4000 quadrature counts the tracking rate would be 9,600 rpm. With a 10.0 kHz excitation and 4000 quadrature counts the tracking rate would be 38,400 rpm. Reducing the counts will increase the tracking rate proportionately.

*** APPLICATIONS ***

- Ideal For Closed Loop Positioning Systems
- Machine Tools
- Servo Motor Control
- Spindle Motor Control
- PLC Positioning Control
- Index/Rotary Tables
- Laboratory Equipment
- Positioning Systems
- Robotic Applications
- Nuclear Applications



*** ADVANCED FEATURES ***

- Easy to Use and Easy to Set Up
- *Absolute Multi-Turn Position Feedback
- 13 Bit Resolution with 11 Bit Turn Count
- Position recovery on Power Up
- Counter Reset Input
- Compatible with Galil Controllers
- Not Sensitive to Controller Reset
- Fast Non-Phase Locked Loop Design (No Lag)
- Highly Accurate
- Tuned Filter for Noise Immunity
- Differential TTL/Line Driver Outputs
- Single +5 vDC Supply Operation
- Loss of Signal Detection
- Fault Signal Output (Line Driver, Open Collector, and Active Pull-Up)
- Status LED's for Power, A, B, Z, Signal HI, Signal MID, and Fault
- Configurable Fault signal conditioning for Fail-Safe operations

- * Tracking limited to +/- 0.25 resolver cycle with power off
- * Absolute Multi-Turn position on SSI interface only

SSI (Synchronous Serial Interface)

The 2790505 Resolver to Digital Converter has a differential SSI interface for applications requiring serial interface. This makes the 2790504 IDEAL for applications where absolute multi-turn resolver feedback is required.

PART NUMBER AND DESCRIPTION

Model	Description
2790505	Resolver to Digital Converter
2790DIN	DIN Rail Mounting Kit
2790CK1	Solder Type Connector Kit
2790CK2	Crimp Type Connector Kit

PEOPLE IN CONTROL OF MOTION

VEGA 2790505 RESOLVER TO ENCODER SPECIFICATIONS AND CONNECTIONS

P1 RESOLVER CONNECTOR

PIN#	FUNCTION	COLOR
1	Sine HI	Red
2	Sine LO	Black
3	Sine Shield	SHLD
4	Cosine HI	Yellow
5	Cosine LO	Blue
6	Cosine Shield	SHLD
7	Feedback HI	Red/Wht
8	Feedback LO	Yel/Wht
9	Feedback Shield	SHLD
10	+5 vDC (*External)	N/A

P2 POWER CONNECTOR

PIN#	FUNCTION	COLOR
*1	+5 vDC	Red
*2	DC Ground	Black

P3 ENCODER CONNECTOR

PIN#	FUNCTION	COLOR
1	DC Ground	Black
2	Channel A+	Grey
3	Channel B+	Yellow
4	Channel Z+	Blue
5	SSI Data-	Grn/Blk
6	SSI Data+	Grn/Wht
7	Reserved	N/A
8	Fault+ (TTL)	N/A
9	Reserved	N/A
10	+5 vDC (*External)	Red
11	Reserved	N/A
12	Reserved	N/A
13	Reserved	N/A
14	Channel A-	Violet
15	Channel B-	Orange
16	Channel Z-	Green
17	Reserved	N/A
18	SSI Counter Reset	Red/Wht
19	!Fault (Active Pull-Up)	Red/Blk
20	Fault- (TTL)	N/A
21	SSI Clock+	Yel/Wht
22	SSI Clock-	Yel/Blk
23	Reserved	N/A
24	Reserved	N/A
25	Active Pull-Up vDC	Blu/Wht

QUADRATURE OUTPUT

The VEGA 2790 series of converter boards use RS-422-A differential drivers to provide 40 mA into a 100 ohm differential load. These outputs are also TTL compatible.

The output latency is dependent on the excitation frequency. At 2.5 kHz the response will be less than 200 uSec and at 10.0 kHz the response will be less than 50 uSec.

Quadrature is provided via Channel A+, Channel A-, Channel B+ and Channel B-. A count is considered to occur whenever there is a transition in either the Channel A or Channel B output signals. The Channel Z (Index) occurs once per resolver cycle. The phase relationship of the two signals indicates the direction of motion as shown in the figure below.

QUADRATURE OUTPUT FORMAT

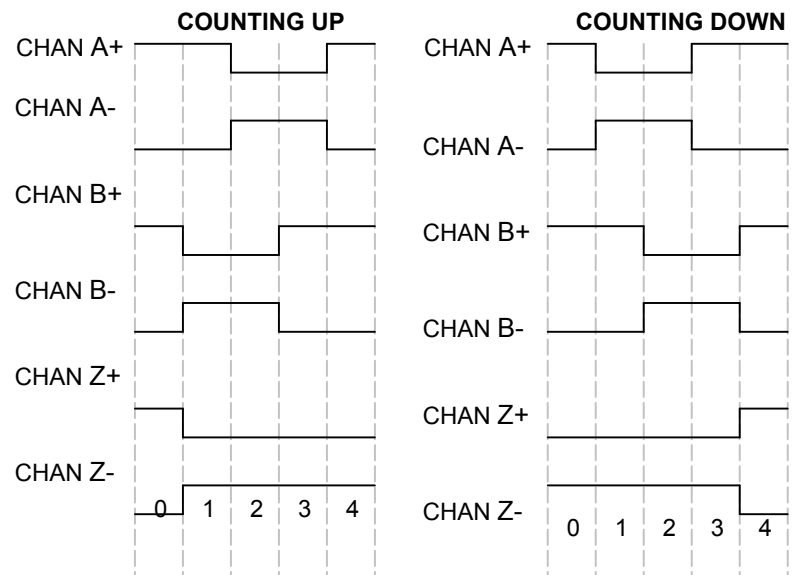

THEORY OF OPERATION

The return signal is internally amplified coarse gain selection (J10). It is then passed thru an active filter network to reduce noise. The advanced tracking algorithm tracks return signal and interpolates A-Quad-B pulses based on the return signal.

The return signal level is monitored for high (HI LED), and low (LO LED) signal level. During fault detection or loss of power to the board the fault relay contacts will open (P1-8 and P1-9), and the A-Quad-B outputs will be tri-stated.

The Z channel (Marker Pulse) will occur once per resolver cycle.

POWER UP SEQUENCE

- 1) The 2790 allows 50 mSec for the power to stabilize and then starts the resolver excitation.
- 2) The 2790 will then initialize the A-Quad-B outputs with channel A, B, and Z (index/marker) to active (high state).
- 3) The 2790 then interpolates out the absolute position in A-Quad-B pulses to the nearest resolver null.



FREQUENCY SELECTION

The 2790 series of converters provide selectable excitation frequencies via SWB1 jumpers B1 and B2. Most Resolver applications are tuned to 2.5 kHz.

The 2790 also provides jumper selection of the active filter network for the return signal to provide the maximum noise immunity at the selected frequency. For the typical Resolver application operating at 2.5 kHz both J10 and J11 jumpers should be installed. For excitation frequencies above 2.5 kHz both jumpers should be removed. For low level signal condition at 2.5 kHz J10 can be removed to achieve a x4 internal gain.

DECIMAL/BINARY SELECTION

The 2790 converter card provides both decimal and binary counting modes. Installing SWB1 jumper B3 selects binary counting mode to provide selection between 256, 512, 1024, and 2048 line counts. Removing jumper B3 selects the decimal counting mode to provide selection between 250, 500, 1000, and 2000 line counts.

CHANNEL Z NORMAL/INVERTED SELECTION

The 2790 converter board provides jumper selectable inversion of the Z Channel (Index) for systems requiring an active low signal. Jumper J2 pins 2-3 select the channel Z Normal mode and pins 1-2 select the Channel Z Inverted mode.

LINE COUNT SELECTION

The 2790 converter board provides 8 jumper selectable line counts. Binary counts are selected by installing SWB1 jumper B3 and installing the appropriate combination of jumpers B4 and B5. Most systems using encoder style feedback are set to the x4 quadrature counting mode so that the effective quadrature counts are 4 times greater than the physical line count of the encoder.

DIFFERENTIAL FAULT SIGNAL SET-UP (J4)

Installing a jumper on J4 pins 1-2 enables the RS-422-A differential drivers and provide up to 40 mA into a 100 ohm differential load. These outputs are also TTL compatible and are located on pins 8 and 20 of the P3 connector.

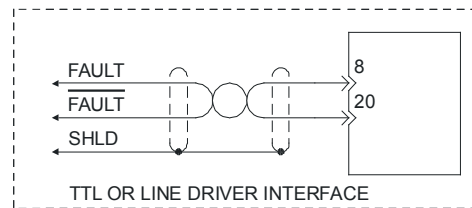

TRI-STATE A-QUAD-B FAULT SIGNAL SET-UP (J4)

Install a jumper on J4 pins 2-3. The 2790 board will Tri-State the A-Quad-B signals during a Fault condition. The Differential Fault signals are also Tri-States and are NOT a valid interface with this set-up. This interface will allow an immediate Fault sense by equipment with loss of signal detection.

ACTIVE PULL-UP FAULT SIGNAL SET-UP

This interface is a fail-safe design so that in a loss of power condition the fault signal on Pin 19 of the P3 connector will be 0 vDC. Pin 19 will be the source voltage with no fault present and can drive up to 600mA. The source voltage for the Pull-up must be provided on Pin 25 of the P3 connector and can range from 5-40 vDC.

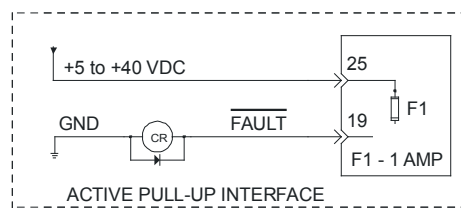

FUNCTION	B1	B2	B3	B4	B5	B6	B7	B8	B9	Quadrature Counts
2.5 kHz	0	0								
5.0 kHz	1	0								
10.0 kHz	0	1								
Reserved	1	1								
Decimal Count			0							
Binary Count			1							
250/256 Lines				0	0					1000 Decimal/1024 Binary
500/512 Lines				1	0					2000 Decimal/4048 Binary
1000/1024 Lines				0	1					4000 Decimal/4096 Binary
2000/2048 Lines				1	1					8000 Decimal/8192 Binary
Default						0	0	0	0	
Reserved						1				
Reserved							1			
Reserved								1		
Reserved									1	

- Figure 1.0 -

1 Indicates installed jumper Indicates default setting

*Requires 13 bits of position data (Available on 2790505 ONLY)

SSI (Synchronous Serial Interface) OUTPUT

The 2790 board's SSI interface provides serial transmission of absolute position data in binary form from the resolver based on a timed clock pulse train from the host device. The SSI differential interface provides a high degree of noise immunity. For each sequential clock pulse from the host device, the 2790 board transmits one data bit from the shift registers of the tracking circuit.

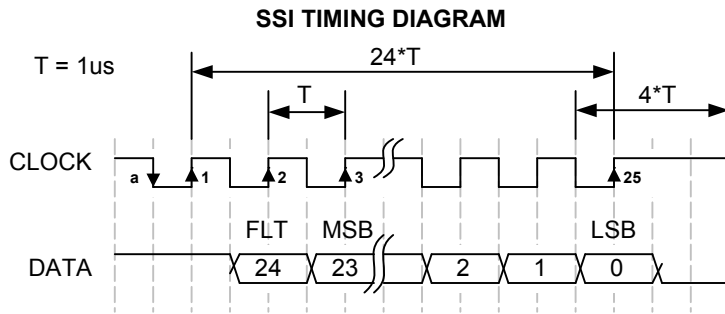

- 1) The 2790 SSI Format is set up for 25 bit transfers.
- 2) The 2790 uses the least significant 13 bits for positional data (8192 counts per rev), and the next 11 most significant bits are used for the turn counter.
- 3) Data is available less than 100ns after the down clock transition and well ahead of the up clock transition at 1mhz clock frequency. The data should be sampled at the up transition of the clock.
- 4) The 2790 is normally interrogated 1000 times/sec.
- 5) The Galil setup string is: **SIX=1,25,13,-1<-10>1**.

TEST POINTS

- GND** = Analog Ground
PA+ = Sine HI (3.6 vDC Peak to Peak)
PA- = Sine LO (3.6 vDC Peak to Peak)
PB+ = Cosine HI (3.6 vDC Peak to Peak)
PB- = Cosine LO (3.6 vDC Peak to Peak)
- SIG** = Signal Return (0.8-18.0 vDC Peak to Peak)
ST1 = Stage 1 Signal (3.8 vDC Peak to Peak)
SCL = Tracking Clock

LED STATUS INDICATORS

- CHA** = Channel A State Indicator
CHB = Channel B State Indicator
CHZ = Channel Z (Index/Marker) Indicator
PWR = Power Status Indicator
- HEA** = Hall Effect A State Indicator (S1)
HEB = Hall Effect B State Indicator (S2)
HEC = Hall Effect C State Indicator (S3)
- FLT** = In Position Fault (detected +/- 16 Counts of Error)
MID = Return Signal Proper Indicator

RESOLVER SET-UP PROCEDURE

- 1) Install the 2790 board as described in the application drawing 2790504.
- 2) Select the fault signal conditioning method by setting the JB4 jumper as described in the JUMPER SETTINGS section based on the application requirements. The DEFAULT is Tri-State A-Quad-B signals with having pins 2 and 3 shorted on J4.
- 3) Select the Z Channel inverted option by setting J2 to short pins 1 and 2. The DEFAULT is non-inverting and having pins 2 and 3 shorted on J2.
- 4) Select the excitation frequency by JB1-2 of SWB1 (see jumper table Fig. 1.0). 2.5 kHz is the DEFAULT setting with Jumper JB1 and JB2 removed.
- 5) Jumpers JB6-8 are reserved on the 2790505 and all jumpers should be removed.
- 6) Select the passive filter setting by J11 for the corresponding frequency setting. The DEFAULT setting is for 2.5 kHz with J11 installed.
- 7) Select the counting style of Binary or Decimal by JB3 of SWB1 (see jumper table Fig. 1.0). For SSI applications the counting style **MUST** be Binary with JB3 installed.
- 8) Select the line count per revolution by setting JB4-5 of SWB1 (see jumper table Fig. 1.0). 2048 lines per revolution (8192 quadrature counts per revolution) is the DEFAULT setting with JB4 removed and JB5 installed. For SSI applications the line count **MUST** be 2048
- 9) Select the Internal gain setting on J10. Installing a jumper on pins 1 and 2 selects a gain of x0.25, installing a jumper on pins 2 and 3 selects a gain of x1.0, and removing the jumper selects a gain of x4.0 The DEFAULT is a gain of x1.0 with the jumper installed on pins 2 and 3 of J10.
- 10) Turn the gain potentiometer fully counter-clockwise. Then turn the gain potentiometer clock-wise until the (Green) MID LED comes on. The signal return on "ST1" test point should now be 3.8 volts peak to peak (1.3 vAC RMS). Phase the position loop if necessary by reversing the Sine HI and Sine LO wires to reverse the count direction. At this point the basic set-up is complete and the position loop can now be closed. Set the position loop gain of the servo system and then continue to Step 11.
- 11) At this point the internal position counters can be preset to the mid range of travel by pressing the manual RESET button or grounding pin 18 of P3. The SSI reset will set the 11 MSB to 0x000, The 12 LSB will be the current shaft position of the resolver.
NOTE: The power **MUST** be on and the board can **NOT** be in a fault condition in order for the SSI reset to preset the internal position counters.
- 12) After the position loop has been closed the phase balance of the 2790 board can be adjusted. To adjust the amplitude balance of the 2790 board, use an AC RMS meter and record the value of PB- to PB+. Then measure the value of PA- to PA+ and adjust the balance pot (BAL) on the 2790 to match the value recorded for PB- to PB+.

TROUBLE SHOOTING

SYMPTOM	CHECKS	SOLUTION
No Power LED	Check +5 vDC	+5 vDC Present → Board Failure – Replace board
Fault LED (Low Signal) Continuous	Remove power and the P1 connector. Ohm between the wires on P1 pin 1 and P1 pin 2, note value. the wires on P1 pin 4 and P1 pin 5, note value.	If resistance values are less than 30 ohms – Check for shorts between P1 pin 1 and P1 pin 2 as well as ground. Check for shorts between P1 pin 4 and P1 pin 5 as well as ground.
	With power on, measure the AC RMS between “PA-“ and “PA+” for 2.3 vAC	Signal not present → Board Failure – Replace board
	With power on, measure the AC RMS between “PB-“ and “PB+” for 2.3 vAC	Signal not present → Board Failure – Replace board
	Measure the AC RMS between “GND” and “STG1” test point for 1.3 vAC	Repeat Step 9-10 of the Resolver Set-Up Procedure
Fault LED (Low Signal) Intermittent	Check “STG1” test point for bounce	Repeat step 12 of the Resolver Set-Up Procedure
	With power on, measure the AC RMS between “PA-“ and “PA+” for 2.3 vAC	Signal not present → Board Failure – Replace board
	With power on, measure the AC RMS between “PB-“ and “PB+” for 2.3 vAC	Signal not present → Board Failure – Replace board
	Remove power and the P1 connector. Ohm between the wires on P1 pin 1 and P1 pin 2, note value. the wires on P1 pin 4 and P1 pin 5, note value.	If resistance values differ by more than 3 ohms of each other → Check resolver windings – Replace slider or cables. If resistance values are less than 30 ohms – Check for shorts between P1 pin 1 and P1 pin 2 as well as ground. Check for shorts between P1 pin 4 and P1 pin 5 as well as ground
Cyclic Error	Check “STG1” test point for bounce	Repeat step 12 of the Resolver Set-Up Procedure
	With power on, measure the AC RMS between “PA-“ and “PA+” for 2.3 vAC	Signal not present → Board Failure – Replace board
	With power on, measure the AC RMS between “PB-“ and “PB+” for 2.3 vAC	Signal not present → Board Failure – Replace board
	Remove power and the P1 connector. Ohm between the wires on P1 pin 1 and P1 pin 2, note value. the wires on P1 pin 4 and P1 pin 5, note value.	If resistance values differ by more than 3 ohms of each other → Check resolver windings – Replace slider or cables. If resistance values are less than 30 ohms – Check for shorts between P1 pin 1 and P1 pin 2 as well as ground. Check for shorts between P1 pin 4 and P1 pin 5 as well as ground
HSG LED (High Signal) Continuous	Measure the AC RMS between “GND” and “STG1” test point for 1.3 vAC	Repeat Step 9-10 of the Resolver Set-Up Procedure
HSG LED (High Signal) Intermittent	Check “STG1” test point for bounce	Follow procedures described in the Fault LED (Low Signal) Intermittent section
MID LED (Signal Midpoint) Continuous	Signal Proper	No Problem... Life is Good
MID LED (Signal Midpoint) Intermittent	Check “STG1” test point for bounce	Repeat step 12 of the Resolver Set-Up Procedure
Counting Polarity is Reversed	None	Swapping the Sine HI with the Sine LO wires will reverse the counting direction
No SSI Data is transferred	None	Swap the Clock+ and Clock- wires

MECHANICAL AND APPLICATION DRAWINGS

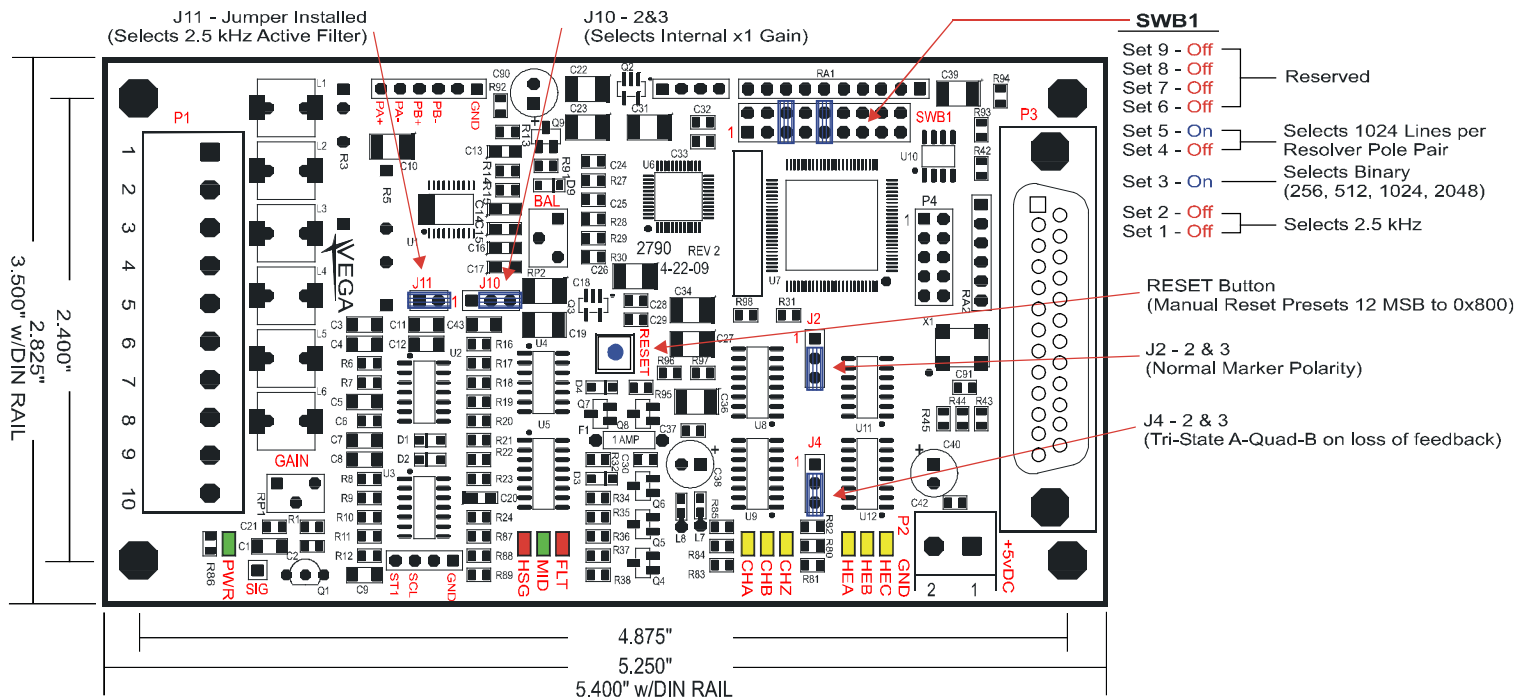
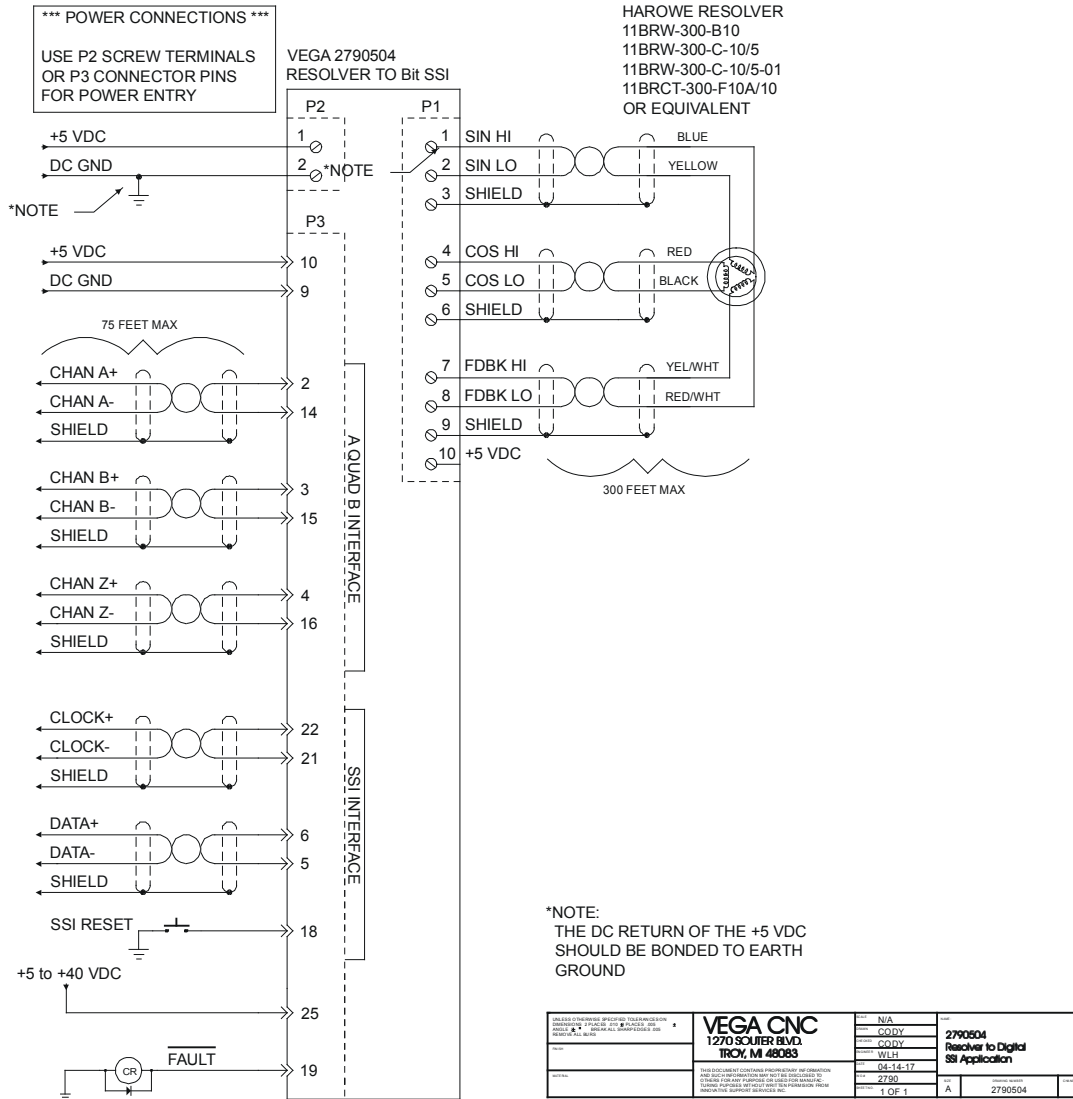

ELECTRICAL

POWER REQUIREMENTS

The 2790505 converter requires +5 vDC supply @ 250 mA for operation. The supplied power should have less than 50 mVolts of noise and drift.

Recommended Power Supplies (If Required)

Mean Well MDR-20-5 (+5 vDC @ 3 Amps)

Mean Well MDR-40-5 (+5 vDC @ 6 Amps)

CABLE SPECIFICATIONS

The 2790 series of converters provide stable and precise sine and cosine excitations. These signals and the return signal are analog and proper routing and shielding techniques should be observed. Shielded twisted pair cables should be used for all interface signals.

Recommended Cable

Shielded Twisted Pair with Drain Wire

Belden #8103 or equivalent

ACCESSORIES

Connector Kits and Mounting Options

KIT #2790CK1

Includes:

- (1) DB-25 Male Solder Cup Connector
- (1) DB-25 Plastic Hood and Hardware

KIT #2790CK2

Includes:

- (1) DB-25 Male Crimp Style Connector
- (25) Gold Male Crimp Pins
- (1) DB-25 Plastic Hood and Hardware

* Use Molex Crimper HTR2445A or similar

KIT #2790DIN

Includes:

- (1) DIN Rail Mount for 2790 boards

REPAIR AND TECHNICAL SUPPORT



12974 Jewell Circle NE
Blaine, MN 55449
248.585.3600

Monday-Friday 8:00am to 6:00pm Central