

VEGA

MODEL 2796517



RESOLVER TO DIGITAL INTERFACE

- Works with Harowe/Danaher, Tamagawa, Kerfott, Singer, AMCI or most any Synchro/Resolver
- Incremental encoder output signals
- Makes resolvers as easy to use as an encoder
- Jumper Selectable counts 1000, 1024, 2000, 2048, 4000, 4096, 8000, and 8192 A-quad-B with Index and complements
- Jumper Selectable Excitation Frequency including 2.5, 5.0, and 10 kHz
- Removable Screw Terminals

With the VEGA 2796517 converter you can have both the ruggedness of a resolver and the digital simplicity of an encoder interface. The 2796517 can be used with almost any resolver. The INDEX/MARKER pulse (Channel Z) will occur once per transducer cycle at the zero degree position.

2796517 SPECIFICATIONS

Excitation:	2.5, 5, or 10 kHz @ 3.6 vpp
Resolver Input:	0.8 to 18 vpp
Power Requirements:	5 vDC @ 250 mA (2796500-05) 24 vDC @ 125 mA (2796500-24)
Drive Capacity:	200 mA Peak
Mechanical:	4.10 x 0.75 x 5.00
Accuracy:	+/- 3 arc minutes typical

RESOLVER TO ENCODER CONVERTER WITH ABSOLUTE POSITION RUN OUT UPON POWER UP

*** APPLICATIONS ***

- Ideal For Closed Loop Positioning Systems
- Machine Tools
- Nuclear Applications
- PLC Positioning Control
- Index/Rotary Tables
- Tracking/Telescope/Telemetry Systems
- Transfer Lines
- Positioning Systems
- Robotic Applications
- Dispensing Systems

*** ADVANCED FEATURES ***

- Incremental Encoder Output (*Absolute within 1 Resolver cycle)
- Non-Phase Locked Loop Design for Faster Loop Closure (Less than 50 uSec @ 10 kHz)
- High Resolution and Highly Accurate
- Tuned Filter for Noise Immunity
- A-Quad-B, Index and Complements
- TTL/Line Driver Outputs
- Quadrature encoder signals to 4 mHz
- Single vDC Supply Operation
- Loss of Phase Detection
- Fault Signal Output (Line Driver, and Active Pull-Up)
- Status LED's for Power, A, B, Z, Signal HI, Signal MID, and Fault
- Configurable Fault signal conditioning for Fail-Safe operations
- Compact Design Only 17.5 mm wide

* Tracking limited to +/- 0.25 Resolver cycle with power off

CONVERTER ACCURACY AND TRACKING RATE

The tracking rate is a function of the excitation frequency and quadrature counts. With a 2.5 kHz excitation and 4000 quadrature counts the tracking rate would be 9,600 rpm. With a 10.0 kHz excitation and 4000 quadrature counts the tracking rate would be 38,400 rpm. Reducing the counts will increase the tracking rate proportionately.

PRICING AND DELIVERY

Model	Description
2796517-05	+5 vDC Resolver to Digital
2796517-24	+24 vDC Resolver to Digital

2796517_Rev. 6

PEOPLE IN CONTROL OF MOTION

VEGA 2796517 RESOLVER TO ENCODER SPECIFICATIONS AND CONNECTIONS

P1 POWER CONNECTOR

PIN#	FUNCTION	COLOR
1	+5 vDC IN (2796517-05 Only)	RED
2	DC Ground	BLK
3	Shield In	SHLD
4	No Connection	N/A
5	Initiate Run Out (IRO) Input	BLU/RED
6	No Connection	N/A
7	Run Out Complete (ROC) Output	BLU/BLK
8	!Fault Output	ORG
9	I/O vDC IN	BLU/WHT
10	+24 vDC IN (2796517-24 Only)	BLU

P2 ENCODER CONNECTOR

PIN#	FUNCTION	COLOR
1	Channel A+	Grey
2	Channel A-	Violet
3	Channel B+	Yellow
4	Channel B-	Orange
5	Channel Z+	Blue
6	Channel Z-	Green
7	Shield Out	SHLD
8	No Connection	N/A
9	No Connection	N/A
10	No Connection	N/A
11	No Connection	N/A
12	No Connection	N/A
13	No Connection	N/A

P4 RESOLVER CONNECTOR

PIN#	FUNCTION	COLOR
1	Feedback LO	Yel/Wht
2	Feedback HI	Red/Wht
3	Shield Out	SHLD
4	Sine LO	Black
5	Sine HI	Red
6	Shield Out	SHLD
7	Cosine HI	Yellow
8	Cosine LO	Blue
9	Shield Out	SHLD
10	DC Ground OUT	N/A
11	+5 vDC OUT	N/A

FAULT SIGNAL INTERFACE

TRI-STATE A-QUAD-B FAULT SIGNAL

The 2796 board will Tri-State the A-Quad-B signals during a Fault condition. This allows receiving devices with A-Quad-B level detection to detect feedback faults without additional fault circuitry.

FAULT SIGNAL OUTPUT (P1-8)

The 2796 will open the contacts of the solid state relay between P1-8 and P1-9 to indicate a fault has occurred. The relay can drive 600 mAmps. The source voltage must be provided on P1-9 and can range from 5-25 vDC.

QUADRATURE OUTPUT

The VEGA 2796 series of converter boards use RS-422-A differential drivers to provide 40 mA into a 100 ohm differential load. These outputs are also TTL compatible.

The output latency is dependent on the excitation frequency. At 2.5 kHz the response will be less than 200 uSec and at 10.0 kHz the response will be less than 50 uSec.

Quadrature is provided via Channel A+, Channel A-, Channel B+ and Channel B-. A count is considered to occur whenever there is a transition in either the Channel A or Channel B output signals. The Channel Z (Index) occurs once per resolver cycle. The phase relationship of the two signals indicates the direction of motion as shown in the figure below.

QUADRATURE OUTPUT FORMAT

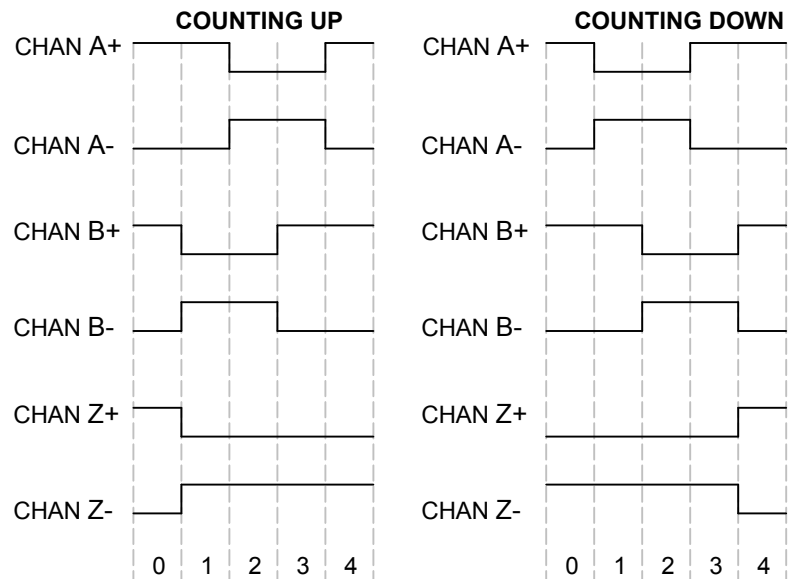

VEGA
 12974 Jewell Circle NE
 Blaine, MN 55449
 248.585.3600

JUMPER SETTINGS (JB1)

FREQUENCY SELECTION (JB1-1 & JB1-2)

The 2796 converters provide selectable excitation frequencies of 2.5, 5.0 and 10.0 kHz via JB1-1 and JB1-2 jumpers.

DECIMAL/BINARY SELECTION (JB1-3)

Installing JB1-3 jumper selects binary counting mode to provide selection between 256, 512, 1024, and 2048 line counts. Removing jumper JB1-3 selects the decimal counting mode to provide selection between 250, 500, 1000, and 2000 line counts.

LINE COUNT SELECTION (JB1-4 & JB1-5)

The 2796 converters board provides 8 jumper selectable line counts. Binary counts are selected by installing JB1-3, while jumpers JB1-4 and JB1-5 select the line count. Most systems are set to the x4 quadrature counting mode so that the effective quadrature counts are 4 times the line count of the encoder.

RESERVED (JB1-6 thru JB1-8)

On the 2796517 converter board Jumpers JB1-6 thru JB1-8 are reserved and should have all jumpers removed.

QUADRATURE POLARITY (JB1-9)

Installing JB1-9 will reverse the polarity of the quadrature.

ACTIVE FILTER SELECTION (JB1-10)

The 2796 also provides jumper selection of the active filter network for the return signal to provide the maximum noise immunity at the selected frequency. For the typical Resolver application operating at 2.5 kHz JB1-10 jumper should be installed. For excitation frequencies above 2.5 kHz JB1-10 jumper should be removed.

INTERNAL GAIN SELECTION (JB1-11 & 12)

The 2796 series of converters provide selectable gain selection via JB1 jumpers 11 and 12. Installing a jumper on JB1-11 selects a gain of x0.25 Installing a jumper on JB1-12 selects a gain of x1.0 and removing the jumpers JB1-11 and JB1-12 selects a gain of x4.0

See Figure 1.0 for JB1 Jumper Chart Below.

THEROY OF OPERATION

The return signal is internally amplified coarse gain selection (JB1-11 & JB1-12). It is then passed thru an active filter network to reduce noise. The advanced tracking algorithm tracks return signal and interpolates A-Quad-B pulses based on the return signal.

The return signal level is monitored for high (HI LED), and low (LO LED) signal level. During fault detection or loss of power to the board the fault relay contacts will open (P1-8 and P1-9), and the A-Quad-B outputs will be tri-stated.

The Z channel (Marker Pulse) will occur once per resolver cycle (resolver pole pair).

POWER UP SEQUENCE

- 1) The 2796 allows 50 mSec for the power to stabilize and then starts the Sine and Cosine excitations.
- 2) The 2796 will then initialize the A-Quad-B outputs with channel A, B, and Z (index/marker) to active (high state).
- 3) The 2796517 waits for the momentary input of the Initiate Run Out (IRO) then interpolates out the absolute position in A-Quad-B pulses to the nearest resolver null. The IRO input is active only once after power up and is ignored there after.
- 4) The 2796517 indicates Run Out Complete (ROC) by closing the contacts between P1-9 and P1-7

FUNCTION	1	2	3	4	5	6	7	8	9	0	1	1	1	QUADRATURE COUNTS
2.5 kHz Excitation	0	0												
5 kHz Excitation	1	0												
10 kHz Excitation	0	1												
Reserved	1	1												
Decimal Count			0											
Binary Count			1											
250/256 Lines				0	0									1000/1024 Counts
500/512 Lines				1	0									2000/2048 Counts
1000/1024 Lines				0	1									4000/4096 Counts
2000/2048 Lines				1	1									8000/8192 Counts
Reserved						0	0	0						
Quadrature+ = CW									0					
Quadrature- = CW									1					
10.0 kHz LPF										0				
2.5-5.0 kHz LPF										1				
x 4.0 Gain Select											0	0		
x 0.25 Gain Select											1	0		
x 1.0 Gain Select											0	1		
Reserved											1	1		

Figure 1.0



Indicates Default

VEGACNC.COM

12974 Jewell Circle NE

Blaine, MN

USA

(248) 585-3600

vegacnc.com

- 1) With the power turned off. Install the 2796 board as described in the application drawing and complete the following steps.
- 2) Select the excitation frequency by setting JB1-1 and JB-2 jumpers as described in the JUMPER SETTINGS (see jumper table Fig. 1.0). 10.0 KHZ is the DEFAULT setting with Jumper JB1-1 removed and JB1-2 installed.
- 3) Select the counting style of Binary or Decimal by setting JB1-3 (see jumper table Fig. 1.0). Binary is the DEFAULT setting with the JB1-3 installed.
- 4) Select the line count per revolution by setting JB1-4 and JB1-5 (see jumper table Fig. 1.0). 2048 lines per revolution (8192 quadrature counts per revolution) is the DEFAULT setting with JB1-4 installed and JB1-5 installed.
- 5) Jumpers JB1-6, JB1-7, and JB1-8 are reserved on the 2796517 board and should be removed
- 6) Select the passive filter setting by JB1-10 for the corresponding frequency setting. The DEFAULT setting is set to 10.0 KHZ and JB1-10 is removed.
- 7) Select the Internal Gain Selection by setting the JB1-11 and JB1-12 jumpers as described in the JUMPER SETTINGS section. The DEFAULT setting is for a board set to x1 Gain JB1-12 installed.
- 8) Starting with the JB1-11 jumper removed and the JB1-12 jumper installed (x1.0 Gain Selection). Turn the ADJ Potentiometer fully counter-clockwise (12 turn Pot) Observing the LO, MID, and HI LEDs apply power to the board.
NOTE: If the MID or HI LEDs are turned on, remove JB1-12 and install JB1-11 (x0.25 Gain Selection).
- 9) Turn the ADJ potentiometer clock-wise until the (Green) MID LED turns on and the LO LED turns off. Continue turning the ADJ clock-wise until the HI LED turns on. Now turn the ADJ potentiometer counter-clockwise to position the ADJ in the middle of the MID LED band.
NOTE: If you are unable to get the MID or HI LED to turn on, remove both JB1-11 and JB1-12 jumpers (x4.0 Gain Selection).
- 10) Phase the position loop if necessary by installing or removing JB1-9 to reverse the count direction. At this point the basic set-up is complete and the position loop can now be closed.
- 11) The amplitude balance of the Sine and Cosine excitations, have been factory set and should not require adjustment. To adjust the phase balance of the 2796 board, observe the excitation return on the "ST1" test point. Adjust the oscilloscope to 50 mvDC per division and offset the signal so that just the peak of the signal is visible. Rotate the resolver at 500-600 rpm. If the phase is unbalanced the peak of the sine wave will bounce and become blurred. Adjust the balance pot on the 2796 to achieve 20 mvDC or less bounce.

LED STATUS INDICATORS

CHA = Channel A State Indicator
CHB = Channel B State Indicator
CHZ = Channel Z (Index/Marker) Indicator
PWR = Power Status Indicator

FLT = 1 Flash = Low Signal Continuous
 2 Flash = High Signal Continuous
 3 Flash 2796512 Only
 PUPV Fault (Power Up Position Valid)
 Power up position detected +/- 15 Counts of Error
 4 Flash = Low Signal Intermittent
 5 Flash = High Signal Intermittent

LO = Loss of Signal Indicator
MID = Return Signal Proper Indicator
HSG = High Signal Indicator

TEST POINTS

ACOM = Analog Ground
PA+ = Sine HI (3.6 vDC Peak to Peak)
PA- = Sine LO (3.6 vDC Peak to Peak)
PB+ = Cosine HI (3.6 vDC Peak to Peak)
PB- = Cosine LO (3.6 vDC Peak to Peak)

SIG = Signal Return (0.8-18.0 vDC Peak to Peak)
ST1 = Stage 1 Signal (3.8 vDC Peak to Peak)

TROUBLE SHOOTING

SYMPTOM	CHECKS	SOLUTION
No Power LED	Check +5 vDC on 2796517-05 or +24 vDC on 2796517-24	vDC Present → Board Failure – Replace board
LO LED (Low Signal) Continuous	Remove power and disconnect P4 from the board. Ohm the wires on P4-1 and P4-2 and note value.	Resistance values are less than 30 ohms – Check for shorts between P4-1 and P4-2 as well as ground.
	Remove power and disconnect P4 from the board. Ohm the wires on P4-4 and P4-5 and note value. Ohm the wires on P4-7 and P4-8 note value.	Resistance values are less than 30 ohms – Check for shorts between P4-4 and P4-5 as well as ground. Check for shorts between P4-7 and P4-8 as well as ground.
	Apply power and measure between P4-4 and P4-5 for 2.9 vRMS	Signal not present → Board Failure – Replace board
	Apply power and measure between P4-7 and P4-8 for 2.9 vRMS	Signal not present → Board Failure – Replace board
	Check “ST1” test point for 3.6 volts peak to peak	Repeat Step 9 of the Resolver Set-Up Procedure
LO LED (Low Signal) Intermittent	Remove power and disconnect P4 from the board. Ohm the wires on P4-4 and P4-5 and note value. Ohm the wires on P4-7 and P4-8 note value.	Resistance values differ by more than 3 ohms of each other → Check resolver windings – Replace cables and/or resolver
	Check “ST1” test point for bounce	Repeat step 11 of the Resolver Set-Up Procedure
Cyclic Error	Check “ST1” test point for bounce	Repeat step 11 of the Resolver Set-Up Procedure
	Remove power and disconnect P4 from the board. Ohm the wires on P4-4 and P4-5 and note value. Ohm the wires on P4-7 and P4-8 note value.	Resistance values are less than 30 ohms – Check for shorts between P4-4 and P4-5 as well as ground. Check for shorts between P4-7 and P4-8 as well as ground.
	Remove power and disconnect P4 from the board. Ohm the wires on P4-4 and P4-5 and note value. Ohm the wires on P4-7 and P4-8 note value.	Resistance values differ by more than 3 ohms of each other → Check resolver windings – Replace cables and/or resolver
HSG LED (High Signal) Continuous	Check “ST1” test point for 3.6 volts peak to peak	Repeat Step 9 of the Resolver Set-Up Procedure
HSG LED (High Signal) Intermittent	Check “ST1” test point for 3.6 volts peak to peak	Follow procedures described in the LO LED (Low Signal) Intermittent section
MID LED (Signal Midpoint) Continuous	Signal Proper	No Problem... Life is Good
MID LED (Signal Midpoint) Intermittent	Check “ST1” test point for bounce	Repeat step 11 of the Resolver Set-Up Procedure
Feedback Polarity is Reversed	None	Installing JB1-9 will reverse the feedback polarity

APPLICATION INTERFACE

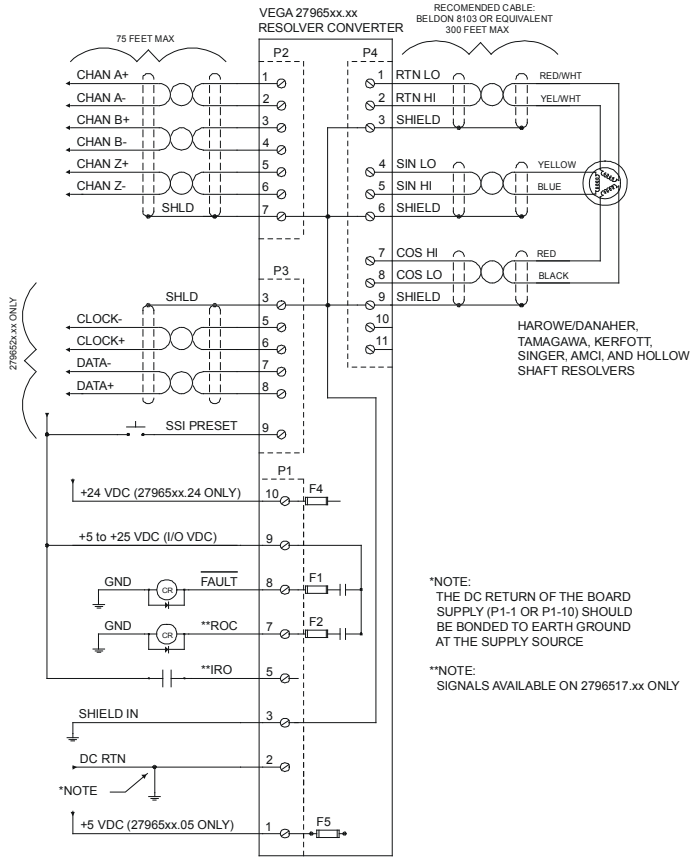

DISASSEMBLY

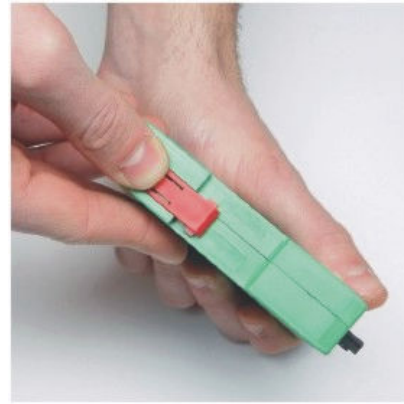

Firmly press the center of the latch hook down and slide towards the center of the enclosure.

NOTE: Use caution not to drop the spring under the latch hook.

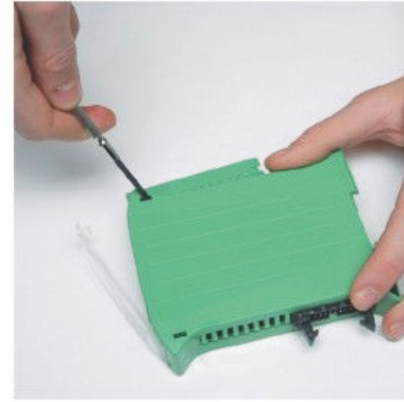

Using a small flat head screwdriver release all four of the enclosure cover hooks.

NOTE: Use caution to avoid breaking the cover hooks.

MECHANICAL

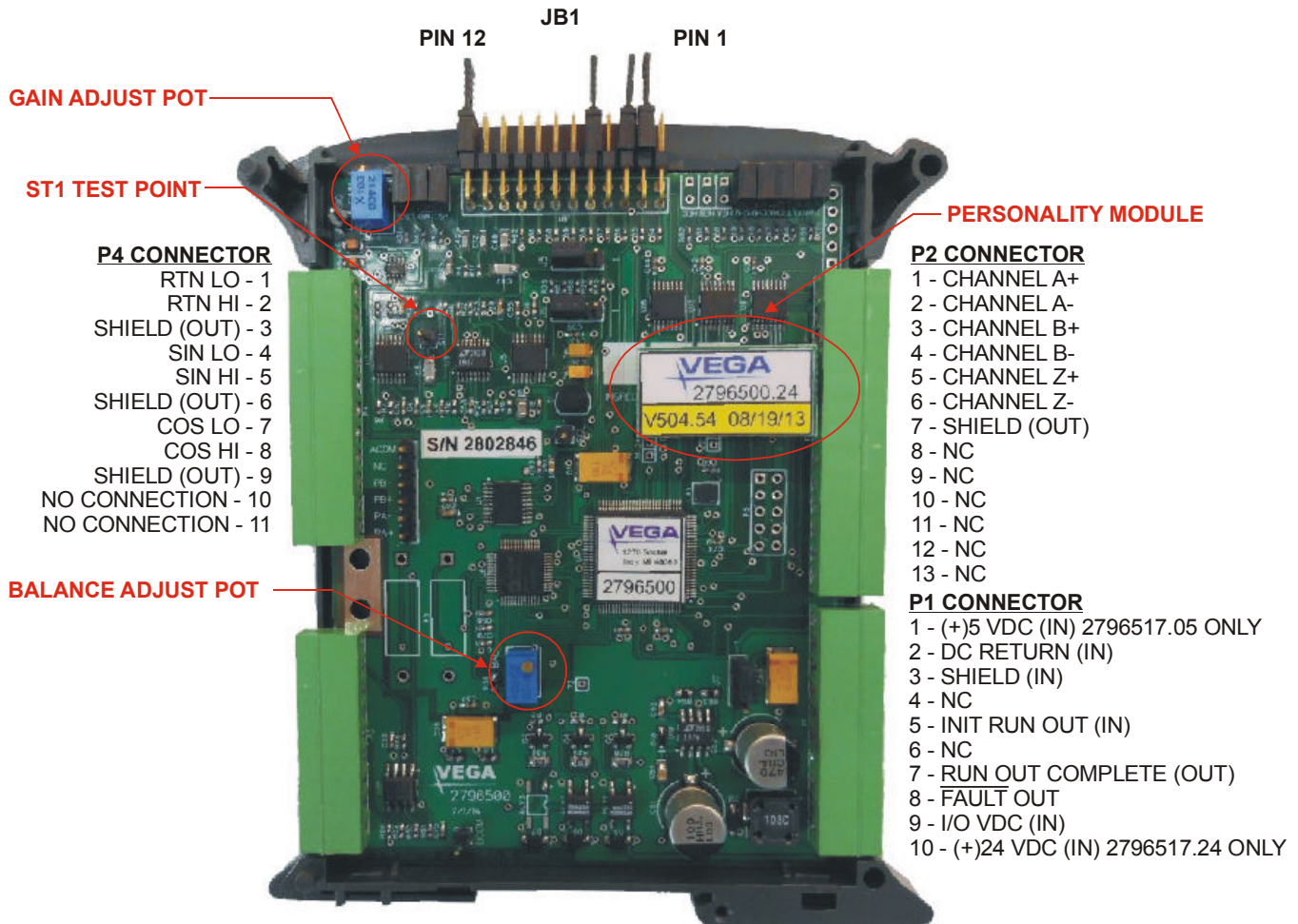

POWER REQUIREMENTS

The 2796517-05 converter requires +5 vDC supply @ 250 mAmp for operation. The 2796517-24 converter requires +24 vDC supply @ 125 mAmp for operation. The supplied power should have less than 50 mVolts of noise and drift.

Recommended Power Supplies (If Required)

TDK DSP30-5 (+5 vDC @ 3 Amps)

TDK DSP60-24 (+24 vDC @ 2.5 Amps)

CABLE SPECIFICATIONS

The 2796 series of converters provide stable and precise sine and cosine excitations. These signals and the return signal are analog and proper routing and shielding techniques should be observed. Shielded twisted pair cables should be used for all interface signals.

Recommended Cable

Shielded (3) Twisted Pair with Drain Wire
Belden #8103 or equivalent



**12974 Jewell Circle NE
Blaine, MN 55449
248.585.3600**

Monday-Friday 8:00am to 6:00pm Eastern